

## Q105/Q110 Label Applicator

The Q105/Q110 label applicator is a simple, rugged, proven labeler designed for moderate speeds and 24/7 operation in harsh environments with minimal maintenance. It is ideal for stand alone applications on existing packaging lines, as well as the labeler of choice for a Quadrel's EconoLine open frame system.

Design features such as Intuitive PLC color touchscreen Controls, 16" label unwind, and upgraded high-torque stepping motor label drive allow for production rates up to 200 parts per minute with +/-1/32" applied accuracy

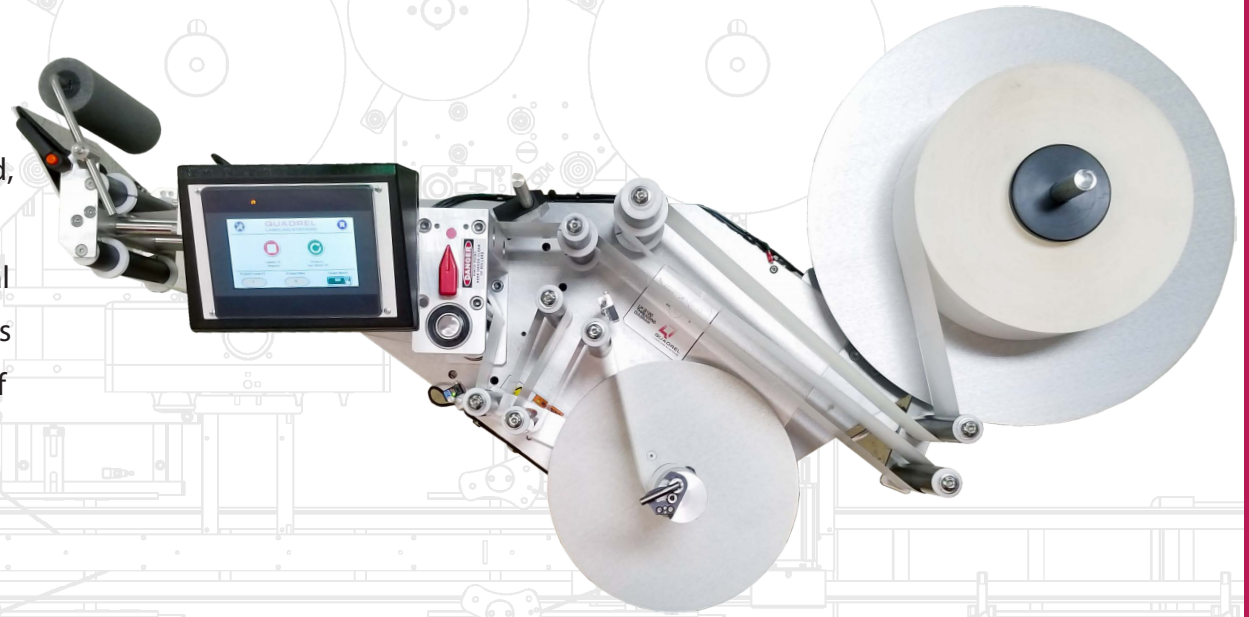

- PLC controls and color touchscreen operator interface
- Password protected menus
- 9 programmable product presets
- Integrated label impresser
- Outboard supported label drive with sealed roller bearings
- Quick disconnect electronics with integrated optical sensors

[www.quadrel.com](http://www.quadrel.com)  
440.602.4700

## QUALITY/ FLEXIBILITY

The Q105/Q110 label applicator is our popular Systems labeling head with integrated electronics. This labeling head provides proven 24/7 reliability in a modular package. In addition, the Q105 labeler offers the flexibility to use one of the most popular labeling heads in the industry for a wide variety of applications.

Ideally suited for simple system integrations, and a wide variety of OEM applications, the Q105 labeling head is the label applicator of choice for continuous operation in with minimal maintenance.

## ADVANCED CONTROLS

The PLC directs and monitors all functions of the labeling head, including speed compensation, fault detection, and full status monitoring. With memory for 20 product presets, the software easily accommodates a wide variety of options with instant recall of product profiles.

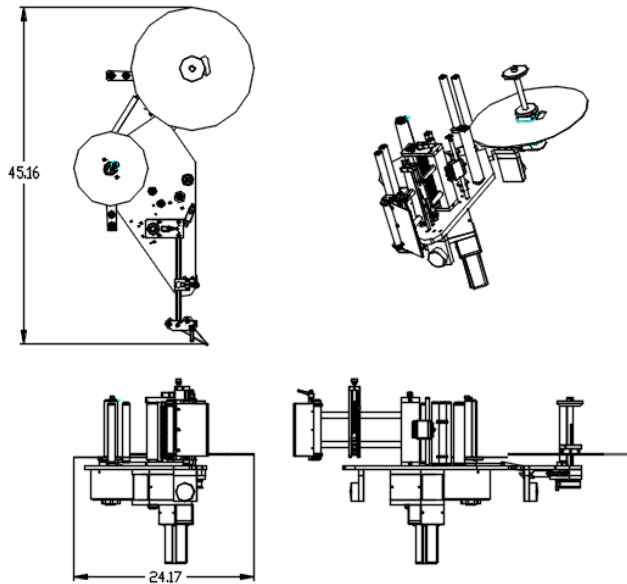

## STANDARD FEATURES

- Intelligent stepper label drive
- Encoder-based speed compensation (with optional encoder)
- Rugged stainless steel & aluminum construction
- Precision sealed bearings
- Outboard supported drive yoke for long-term reliability and consistent web tracking
- Dependable performance in harsh environments
- 16" (406mm) label unwind for less frequent roll changes
- Optical label detection sensor
- Integrated fan-cooled electronics

## OPTIONS

- Left or Right hand versions
- T or H-Base stand with casters and leveling pads
- Low label detection
- End of web detection
- Broken web detection
- Thermal transfer, laser, or hot stamp imprinter
- Clear label detection
- Push Pull label drive
- Pivoting Peel Plate
- Consult factory for others
- Upgraded Stepping motor label drive with adjustable hydraulic waste rewind clutch (Q110)

## SPECIFICATIONS

**Size:** 24"(610mm) width x 47" (1194mm) length  
**Approximate Net Shipping Weight:** 80 lbs.(36kg)  
**Actual Labeling Rate:** Dependent upon label length and product size (Up to 200 products per minute)  
**Dispensing Accuracy:** Up to +/-1/32" (1mm)  
**Dispensing Speed:** Variable, up to 1200" per minute  
**Label Drive:** Stepping motor standard.  
**Design Features:** Outboard supported label drive, stainless steel/aluminum construction, precision sealed bearing, pivoting peel plate  
**Label Dimensions:**  
Maximum width = 6 7/8"(174mm), 9 7/8" (254mm) optional  
Maximum length = required length  
Minimum width 1/2" (13mm)  
Minimum length = 1/2" (13mm)  
**Roll Capacity:** 16" (406mm) O.D. on 3" (76mm) or 6" (153mm) I.D. core (Must specify at time of order)  
**Web Width:** 7" (177mm), 10"(254mm) optional  
**Label Format:** Die cut, waste removed (Minimum 1/8" [3mm] between labels)  
**Label Sensing:** Photoelectric  
**Utilities:** 110vac or 220vac, 50/60Hz, 10/5 amps

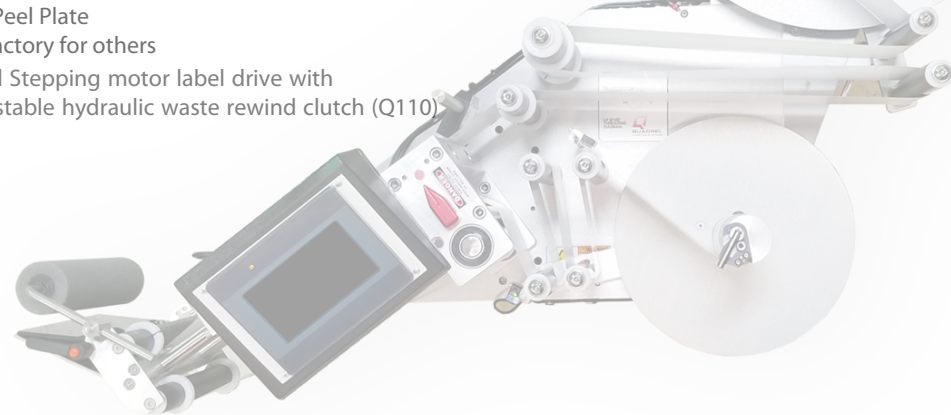

**QUADREL**  
LABELING SYSTEMS